

PUNZÓN DE PRECISIÓN DIN 9861 FORMA D

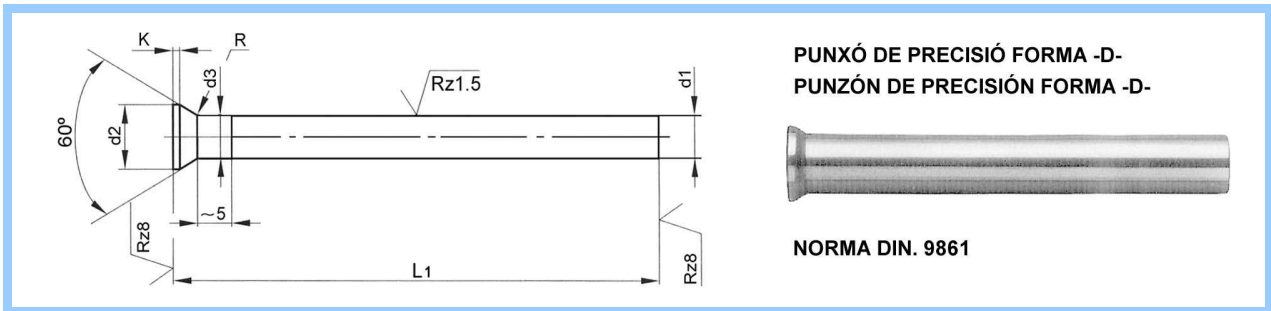

PUNZÓN DE PRECISIÓN FORMA -D-
PUNZÓN DE PRECISIÓN FORMA -D-

NORMA DIN. 9861

MATERIAL: HWS -Acero al 12% CROMO
HSS -Acero Súper Rápido 1.3343
ASP/K-190 -Acero Pulvimetalúrgico
H10-F -Metal duro integral

DUREZAS: HWS -Vástago 60/62 Hrc. Cabeza 40/50 Hrc.
HSS -Vástago 62/64 Hrc. Cabeza 50/55 Hrc.
ASP/K-190 -Vástago 63/65 Hrc. Cabeza 40/50 Hrc.
H10-F -1600 HV30/92, 1 Hra.

EJECUCIÓN: TEMPLADOS, RECTIFICADOS Y LAPEADOS. CABEZA ESTAMPADA EN CALIENTE.
BAJO DEMANDA, LONGITUD 125 ó 130 – 160 mm. Y TRATAMIENTOS SUPERFICIALES, TIN., TIN-C., ECT.

d ₁ h6	d ₂	Escalonado	K+0.2	L ₁
0.50	0.90	0.05	0.20	71
0.55	1.00			
0.60	1.10			
0.65	1.20			
0.70- 0.75	1.30			
0.80- 0.85	1.40			
0.90- 0.95	1.60			
1.00- 1.10	1.80			
1.20- 1.30	2.00			
1.40- 1.50	2.20			
1.60- 1.70	2.50	0.10	0.40	71 – 80 – 100 125 ó 130
1.80- 1.90	2.80			
2.00	3.00			
2.10- 2.20	3.20			
2.30- 2.50	3.50			
2.60- 2.90	4.00			
3.00- 3.40	4.50			
3.50- 3.90	5.00			
4.00- 4.40	5.50			
4.50- 4.90	6.00			
5.00- 5.40	6.50	0.50	1.00	71 – 80 – 100 125 ó 130
5.50- 5.90	7.00			
6.00- 6.40	8.00			
6.50-7.40	9.00			
7.50- 8.40	10.00			
8.50- 9.40	11.00			
9.50- 10.40	12.00			
10.50- 11.40	13.00			
11.50- 12.00	14.00			
12.50- 13.00	15.00		1.00	
13.50- 14.00	16.00			
14.50- 15.00	17.00			
15.50- 16.00	18.00			
16.50- 17.00	19.00			
17.50- 18.00	29.00			
18.50- 19.00	21.00			
19.50- 20.00	22.00			
21.00	23.00			
22.00	24.00	1.00		
23.00	25.00			
24.00	26.00			
25.00	27.00			